

**S42 - Wafer / S43 - Lug**

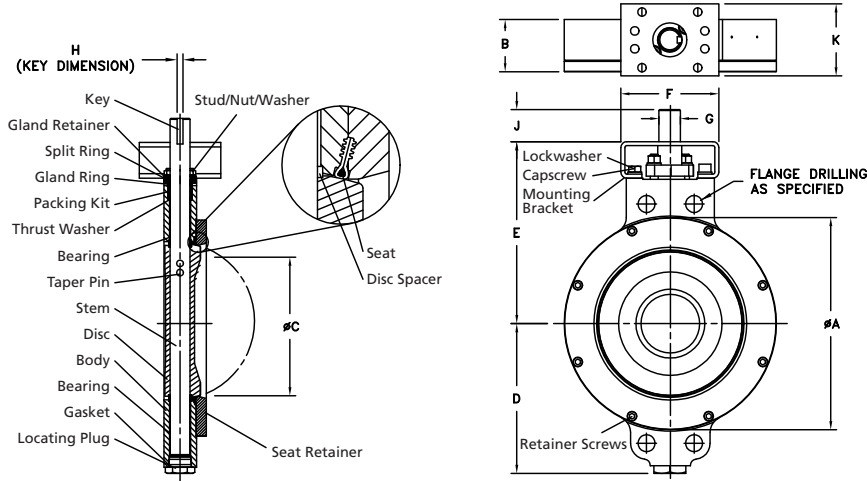

**IMPERIAL DIMENSIONS: Inches**

Valve Size	A	B	C	D	E	F	Top Plate Drilling			G	H	J	K	L	Weight (lbs.)	Lug Bolting Data			Weight (lbs.)
							BC	No of Holes	Hole Dia.							BC	No. of Holes	Threads UN-2B	
2½	4.75	1.88	2.28	3.81	6.38	4.36	2.76	4	0.38	0.63	0.43	1.25	2.5	0.77	15	5.88	8	¾-10	13
3	5.25	1.88	2.86	4.09	6.63	4.36	2.76	4	0.38	0.63	0.43	1.25	2.5	0.77	17	6.62	8	¾-10	16
4	6.75	2.03	3.72	4.71	7.5	4.36	2.76	4	0.38	0.63	0.43	1.25	2.5	0.75	23	7.88	8	¾-10	20
5	8.25	2.23	4.8	5.13	8.0	5.12	2.76	4	0.38	0.75	0.51	1.25	4.5	0.94	39	9.25	8	¾-10	33
6	8.88	2.42	5.75	6.25	8.75	5.12	4.92	4	0.53	0.87	0.63	1.25	4.5	0.97	54	10.62	12	¾-10	40
8	10.94	2.82	7.56	7.55	10.0	6.12	4.92	4	0.53	1.18	0.87	2.0	4.5	1.1	89	13.0	12	7/8-9	68
10	13.26	3.28	9.44	9.36	11.38	6.12	4.92	4	0.53	1.38	.39 x .39	2.0	4.5	1.28	144	15.25	16	1-8	113
12	15.57	3.62	11.31	10.89	13.5	7.75	4.92	4	0.53	1.38	.39 x .39	2.0	6.5	1.4	217	17.75	16	1½-8	173
14	17.9	4.66	11.38	12.5	18.25	10.38	6.5	4	0.81	1.97	.47 x .39	2.5	6.5	2.13	444	20.25	20	1½-8	328
16	19.94	5.35	14.31	13.88	21.0	10.38	6.5	4	0.81	2.5	.62 x .62	4.0	6.5	2.5	592	22.5	20	1½-8	455
18	22.0	5.98	15.0	15.43	21.0	15.38	10.0	8	0.67	2.5	.62 x .62	4.0	11.75	2.65	856	24.75	24	1½-8	605
20	24.1	6.34	16.5	16.8	22.25	15.38	10.0	8	0.67	3.0	.75 x .75	4.0	11.75	2.9	1050	27.0	24	1½-8	780
24	28.88	7.15	20.68	19.8	26.25	19.5	11.73	8	0.81	3.5	.88 x .62	5.25	13.5	3.4	1720	32.0	24	1½-8	1260
30	35.12	8.98	26.81	23.4	32.25	24.0	14.02	8	1.25	4.5	1.0 x .75	5.25	16.0	4.38	3010	39.25	28	1¾-8	2260
36	42.0	10.67	33.13	27.12	36.25	24.0	14.02	8	1.25	5.0	1.25 x .88	6.0	16.0	5.23	4400	46.0	32	2-8	3320
42	50.75	11.5	38.88	29.25	40.5	26.0	15.98	8	1.5	6.0	1.5 x 1.0	6.5	18.7	5.13	4700	47.5	32	1½-8	5000
48	57.75	12.5	45.75	33.16	44.75	29.0	19.02	12	1.5	7.0	1.75 x 1.5	7.5	22.0	5.5	7000	54.0	32	1½-8	—

**METRIC DIMENSIONS: Millimeters**

Valve Size	A	B	C	D	E	F	Top Plate Drilling			G	H	J	K	L	Weight (kg.)	Lug Bolting Data			Weight (kg.)
							BC	No of Holes	Hole Dia.							BC	No. of Holes	Threads UN-2B	
65	121	48	58	97	162	111	70	4	9.6	16	11	32	64	20	7	149	8	¾-10	6
80	133	48	73	104	168	111	70	4	9.6	16	11	32	64	20	8	168	8	¾-10	7
100	171	52	94	120	191	111	70	4	9.6	16	11	32	64	19	10	200	8	¾-10	9
125	210	57	122	130	203	130	70	4	9.6	19	13	32	114	24	18	235	8	¾-10	15
150	226	61	146	159	222	130	125	4	13.5	22	16	32	114	25	25	270	12	¾-10	18
200	278	72	192	192	254	155	125	4	13.5	30	22	51	114	28	40	330	12	7/8-9	31
250	337	83	240	238	289	155	125	4	13.5	35	10 x 10	51	114	33	65	387	16	1-8	51
300	395	92	287	277	343	197	125	4	13.5	35	10 x 10	51	165	36	99	451	16	1½-8	78
350	455	118	289	318	464	264	165	4	20.5	50	12 x 10	64	165	54	202	514	20	1½-8	149
400	506	136	363	353	533	264	165	4	20.5	64	16 x 16	102	165	64	269	572	20	1½-8	206
450	559	152	381	392	533	391	254	8	17.0	64	16 x 16	102	298	67	389	629	24	1½-8	274
500	612	161	419	427	565	391	254	8	17.0	76	19 x 19	102	298	74	477	686	24	1½-8	354
600	734	182	525	503	667	495	298	8	20.5	89	22 x 16	133	343	86	781	813	24	1½-8	572
750	892	228	681	594	819	610	356	8	31.7	114	25 x 19	133	406	111	1367	997	28	1¾-8	1025
900	1067	271	842	689	921	610	356	8	31.7	127	32 x 22	152	406	133	1998	1168	32	2-8	1506
1050	1289	292	988	743	1029	660	406	8	38.1	152	38 x 25	165	475	130	2134	1207	32	1½-8	2268
1200	1467	318	1162	842	1137	737	483	12	38.1	178	44 x 38	191	559	140	3178	1372	32	1½-8	—

Drawings are for reference only. Please refer to Bray ES drawings on the Bray website, www.bray.com. Bray reserves the right to change product dimensions without notice.

Inquire/P.O. No.: \_\_\_\_\_

Bray Order No.: \_\_\_\_\_

**SR Drawing #42/43-2.5/48-im** August 2012- Rev. 0

Pg. 4 Customer/Project: \_\_\_\_\_