

**Series 35-36 Double Flange**

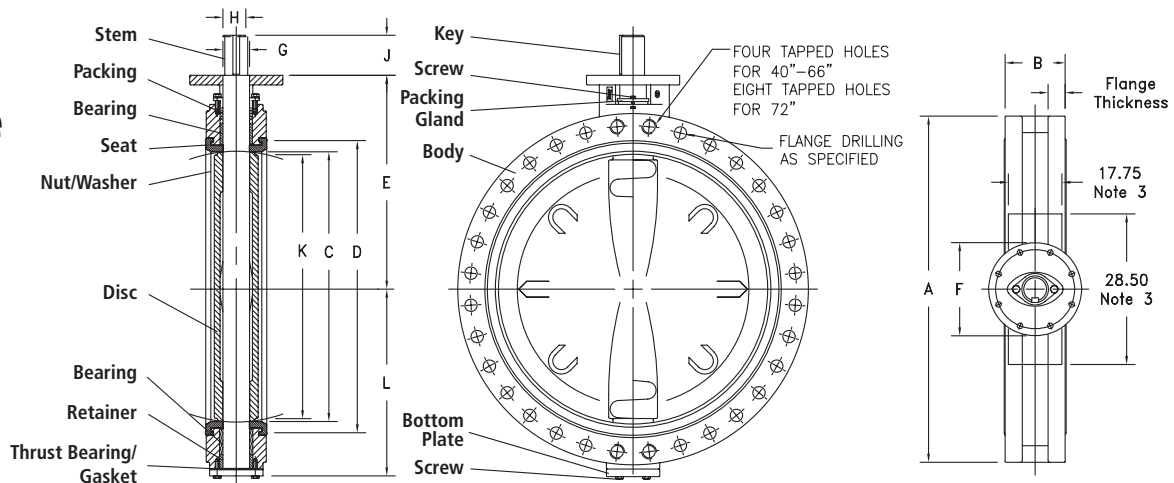

- NOTES:  
 1. K dimension is disc cordial dimension of valve face.  
 2. \* Denotes preliminary dimensions.  
 3. These dimensions apply ONLY to the size 72".

IMPERIAL DIMENSIONS: Inches		ANSI Class 125/150 Valves																		
Valve Size Ins	A	B	C	D	E	F	Mounting Flange Drilling			G	SERIES 35				SERIES 36				L	Weight (lbs.)
							PCD	No. Holes	Hole Dia.		H	J	Key Size	K	H	J	Key Size	K		
22	31.25	6.06	21.27	24.12	20.12	8.27	6.50	4	.81	2.50	2.50	4.00	.62x.62	20.51	2.50	4.00	.62x.62	20.56	16.56	475
24	33.00	5.94	23.28	25.75	19.50	8.27	6.50	4	.81	2.50	2.50	4.00	.62x.62	22.65	2.50	4.00	.62x.62	22.70	17.56	500
26	35.25	6.50	24.46	27.83	21.83	11.81	10.00	8	.71	2.50	2.50	4.00	.62x.62	23.71	2.50	4.00	.62x.62	23.76	18.82	675
28	37.80	6.50	26.46	29.83	22.84	11.81	10.00	8	.71	2.50	2.50	4.00	.62x.62	25.74	2.50	4.00	.62x.62	25.79	19.83	735
30	38.75	6.56	29.29	32.14	23.00	11.81	10.00	8	.71	3.00	2.50	4.00	.62x.62	28.68	3.00	4.00	.75x.75	28.73	20.81	855
32	41.75	7.48	30.39	33.78	26.38	11.81	10.00	8	.71	3.00	2.50	4.00	.62x.62	29.59	3.00	4.00	.75x.75	29.64	21.94	1010
34	44.69	7.88	33.00	35.82	26.93	13.78	11.73	8	.81	3.50	3.00	4.00	.75x.75	32.18	3.50	5.25	.88x.62	32.23	23.66	1165
36	46.00	7.88	35.30	38.25	27.75	13.78	11.73	8	.81	3.50	3.00	4.00	.75x.75	34.57	3.50	5.25	.88x.62	34.62	24.94	1320
40	50.75	8.50	38.27	41.66	30.79	13.78	11.73	8	.81	4.00	3.50	5.25	.88x.62	37.44	4.00	5.25	1.0x.75	37.49	26.56	2140
42	53.00	9.88	41.25	44.62	32.00	13.78	11.73	8	.81	4.00	3.50	5.25	.88x.62	40.21	4.00	5.25	1.0x.75	40.26	27.81	2550
44	55.25	9.88	43.25	46.72	33.12	13.78	11.73	8	.81	4.00	3.50	5.25	.88x.62	42.24	4.00	5.25	1.0x.75	42.29	29.06	2800
48	59.50	10.88	47.25	50.62	36.00	16.34	14.02	8	1.28	5.00	4.00	5.25	1.0x.75	46.16	5.00	6.00	1.25x.88	46.21	31.06	3200
52	Consult Factory																			
54	69.00	15.00	54.00	57.50	40.62	13.78	11.73	8	.81	6.00	5.00	5.25	1.25x.88	52.02	—	—	—	—	37.25	6000
54	69.00	15.00	54.00	57.50	40.62	16.34	14.02	8	1.28	6.00	—	—	—	—	6.00	6.50	1.5x1.0	52.06	37.25	6000
56	Consult Factory																			
60	73.00	15.00	58.39	63.07	44.31	16.34	14.02	8	1.38	7.00	6.00	6.50	1.5x1.0	56.67	—	—	—	—	39.12	7000
60	73.00	15.00	58.39	63.07	44.31	18.70	15.98	8	1.56	7.00	—	—	—	—	7.00	7.50	1.75x1.5	56.72	39.12	7000
64	Consult Factory																			
66	80.00	18.00	65.12	70.04	48.75	16.34	14.02	8	1.38	7.00	6.00	6.50	1.5x1.0	62.84	—	—	—	—	43.80	8000
66	80.00	18.00	65.12	70.04	48.75	18.70	15.98	8	1.56	7.00	—	—	—	—	7.00	7.50	1.75x1.5	62.88	43.80	8000
72	86.50	18.00	69.22	73.90	52.25	22.05	15.98	8	1.56	8.50	7.50	8.00	1.75x1.5	67.06	—	—	—	—	46.92	11250
72	86.50	18.00	69.22	73.90	52.25	22.05	19.02	12	1.56	8.50	—	—	—	—	8.50	10.00	2.0x1.5	67.10	46.92	11250
78	93.00	18.00	76.37	81.29	55.00	27.00	19.02	12	1.31	8.50	7.50	8.00	1.75x1.5	74.49	—	—	—	—	51.28	12950
78	93.00	18.00	76.37	81.29	55.00	27.00	19.02	12	1.56	8.50	—	—	—	—	8.50	8.50	2.0x1.5	74.54	51.28	12950
84	99.76	18.00	82.62	87.54	58.88	27.00	23.74	20	1.31	9.50	8.50	8.50	2.0x1.5	80.91	—	—	—	—	55.66	14500
84	99.76	18.00	82.62	87.54	58.88	27.00	23.74	20	1.56	9.50	—	—	—	—	9.50	10.00	2.5x1.75	80.96	55.66	14500
90	Consult Factory																			
96	Consult Factory																			

Drawings are for reference only. Please refer to Bray ES drawings on the Bray website, www.bray.com. Bray reserves the right to change product dimensions without notice.

**SR Drawing #35/36-22/96-in** January - 2015

Inquire/P.O. No.: \_\_\_\_\_

Customer/Project: \_\_\_\_\_

Bray Order No.: \_\_\_\_\_

**Series 35-36 Double Flange**

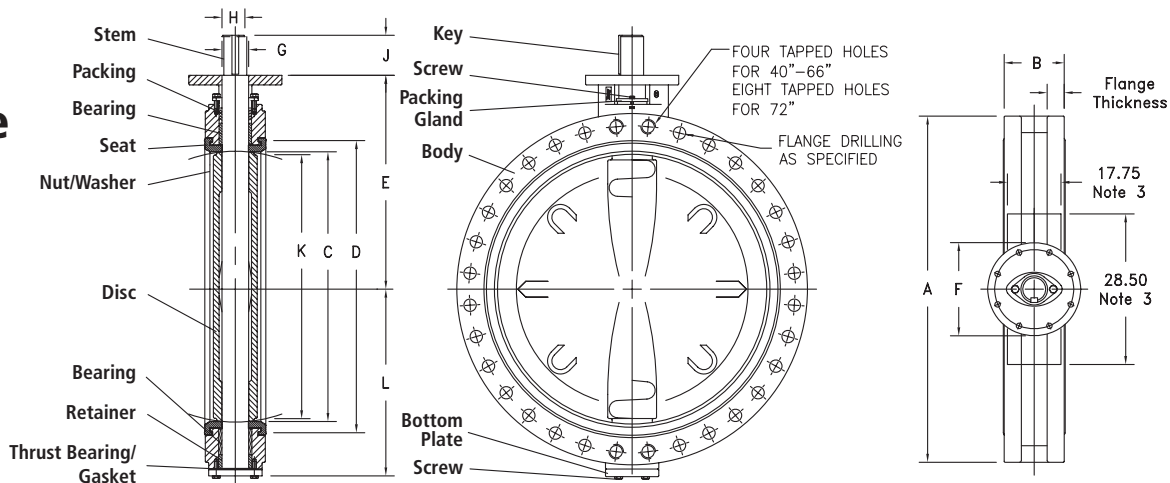

- NOTES:  
 1. K dimension is disc cordial dimension of valve face.  
 2. \* Denotes preliminary dimensions.  
 3. These dimensions apply ONLY to the size 72".

**METRIC DIMENSIONS: Millimeters ANSI Class 125/150 Valves**

Valve Size mm							Mounting Flange Drilling			SERIES 35					SERIES 36					Weight (kg)
	A	B	C	D	E	F	PCD	No. Holes	Hole Dia.	G	H	J	Key Size	K	H	J	Key Size	K	L	
550	794	154	540	613	511	210	165	4	21	64	64	102	16 x 16	521	64	102	16 x 16	9	421	215
600	838	151	591	654	495	210	165	4	21	64	64	102	16 x 16	575	64	102	16 x 16	10	446	227
650	895	165	621	707	554	300	254	8	18	64	64	102	16 x 16	602	64	102	16 x 16	11	478	306
700	960	165	672	758	580	300	254	8	18	64	64	102	16 x 16	654	64	102	16 x 16	12	504	333
750	984	167	744	816	584	300	254	8	18	76	64	102	16 x 16	728	76	102	19 x 19	13	529	388
800	1060	190	772	858	670	300	254	8	18	76	64	102	16 x 16	752	76	102	19 x 19	13	557	458
850	1135	200	838	910	684	350	298	8	21	89	76	102	19 x 19	817	89	133	22 x 16	818	601	528
900	1168	200	897	972	705	350	298	8	21	89	76	102	19 x 19	878	89	133	22 x 16	879	633	599
1000	1289	216	972	1058	782	350	298	8	21	102	89	133	22 x 16	951	102	133	25 x 19	952	675	971
1050	1346	251	1048	1133	813	350	298	8	21	102	89	133	22 x 16	1021	102	133	25 x 19	1022	706	1157
1100	1403	251	1099	1187	841	350	298	8	21	102	89	133	22 x 16	1073	102	133	25 x 19	1074	738	1270
1200	1511	276	1200	1286	914	415	356	8	33	127	102	133	25 x 19	1172	127	152	32 x 22	1174	789	1451
1300	CONSULT FACTORY																			
1350	1753	381	1372	1461	1032	350	298	8	21	152	127	133	32 x 22	1321	—	—	—	—	946	2722
1350	1753	381	1372	1461	1032	415	356	8	33	152	—	—	—	—	152	165	38 x 25	1322	946	2722
1400	CONSULT FACTORY																			
1500	1854	381	1483	1602	1125	415	356	8	35	178	152	165	38 x 25	1439	—	—	—	—	994	3175
1500	1854	381	1483	1602	1125	475	406	8	40	178	—	—	—	—	178	191	45 x 38	1441	994	3175
1600	CONSULT FACTORY																			
1650	2032	457	1654	1779	1238	415	356	8	35	178	152	165	39 x 25	1596	—	—	—	—	1113	3629
1650	2032	457	1654	1779	1238	475	406	8	40	178	—	—	—	—	178	191	45 x 38	1597	1113	3629
1800	2197	457	1758	1877	1327	560	406	8	40	216	191	203	45 x 38	1703	—	—	—	—	1192	5103
1800	2197	457	1758	1877	1327	560	483	12	40	216	—	—	—	—	216	254	51 x 38	1704	1192	5103
2000	2362	457	1940	2065	1397	686	483	12	33	216	191	203	45 x 38	1892	—	—	—	—	1303	5874
2000	2362	457	1940	2065	1397	686	483	12	40	216	—	—	—	—	216	216	51 x 38	1893	1303	5874
2100	2534	457	2099	2224	1496	686	603	20	33	241	216	216	51 x 38	2055	—	—	—	—	1414	6577
2100	2534	457	2099	2224	1496	686	603	20	40	241	—	—	—	—	241	254	64 x 45	2056	1414	6577
2200	CONSULT FACTORY																			
2400	CONSULT FACTORY																			

Drawings are for reference only. Please refer to Bray ES drawings on the Bray website, www.bray.com. Bray reserves the right to change product dimensions without notice.

**SR Drawing #35/36-22/96-m** January - 2015

Inquire/P.O. No.: \_\_\_\_\_

Customer/Project: \_\_\_\_\_

Bray Order No.: \_\_\_\_\_